



## Sensor Activated Electronic Counter Mounted Soap Dispenser **KS15 - 1000**

### ENGINEERING SPECIFICATION:

Sleek chrome plated finish hands-free soap dispenser. Refillable reservoir capacity of (27 fl. oz.) 800ml with economical measured dose to reduce soap consumption. Infrared sensor lens has an activation range of 3-4". Power supply utilizes 4 alkaline AA batteries (not included) and comes complete with spout, sensor, power module and mounting hardware. Ideal for both retrofit and new construction applications (fits existing 1" opening on retrofits).

### TECHNICAL/PERFORMANCE SPECIFICATIONS:

Power supply utilizes 4 alkaline AA batteries (not included)

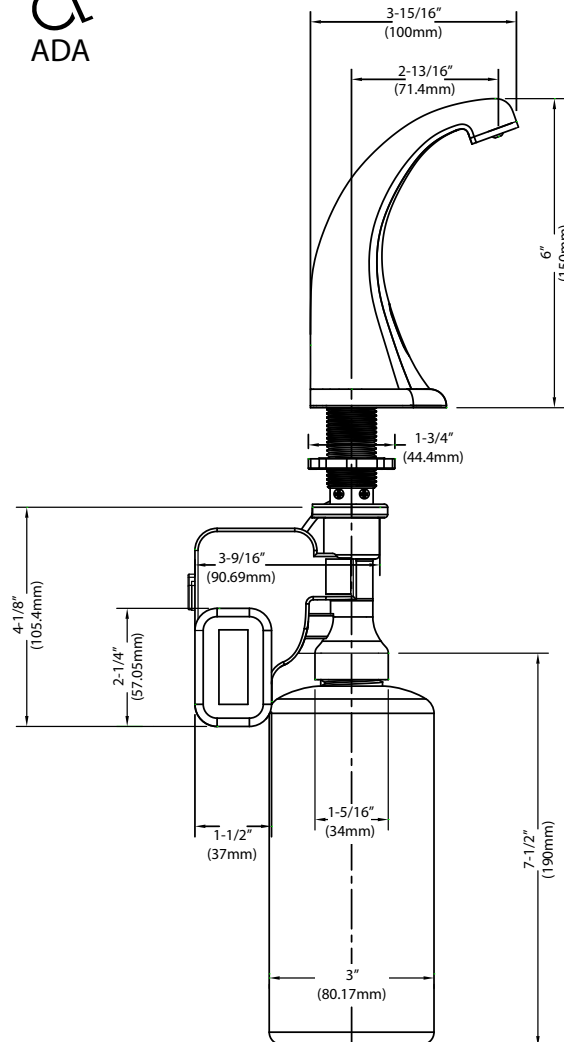

Dimensions shown in inches (mm) are for reference only and are subject to change.